

1 About

NC-EAS(Y)©

Controlling the CNC milling machines in the Windows systems



Copyright © 1993 - 2006 by Michael Boenigk

Internet: www.easgmbh.de
E-Mail: service@easgmbh.de

It is FORBIDDEN to copy the software or any of the printed materials either in one piece or in parts regardless of whether the software or materials are in their original or altered version.

All the data carriers have been checked and tested before dispatch for the presence of viruses or errors. It is recommended, however, that the client additionally controls the data carriers. EAS GmbH is not liable for any potential damage arising from the use of their programs / software.

It is FORBIDDEN to remove the **LICENCE NUMBER** from the software and to modify or disassemble the programme. **All the COPIES** must comply with and be identical with the supplied original. As a safety measure, it is ALLOWED to make ONE copy of the program.

2 Basics

The NC-EAS(Y) software is a program for controlling and operating CNC milling machines with three stepper motors. Command signals are sent via a parallel port (LPT) or a USB port to the power drivers and then to the built-in stepper motors of the CNC machine. The program also reads and indicates the condition of the three limit reference-switches, the emergency STOP switch, the material height sensor or the tool-length sensor. Two command signals, independent of the other signals, are used for the switching on, with the aid of relays, of the mill spindle motor and the coolant pump.

The WINDOWS operating system does not allow, without the application of an extra external unit (a special controller), for steering in real time. This is because in the Windows system the timer is used for performing multi-task activities. Thus the stepper motors are driven with the aid of an external EAS USB Controller controller which performs, among other tasks, the task of the timer, emits the heartbeat signal and the direction signals for driving the 4 stepper motors.

2.1 What the NC-EAS(Y) program can do?

The NC-EAS(Y) software has an innovative graphic interface. It is clearly devised and easy to operate. All the main functions have been equipped with their respective icons and shortcut keys. The CAD-similar interface of the software presents the working scope /area of the CNC machine, which includes all the elements, e.g. drawing data, material, zero point, park point or the display of the scan/measurement point.

The NC-EAS(Y) program is mostly used for performing the following work:

- milling
- drilling / boring
- foil cutting
- engraving
- height scan/measurement
- drawing
- Processing into digital format

2.2 What you need additionally?

The list below presents all the components (hardware and software) essential in order to use the NC-EAS(Y) program:

- Operating system: **Windows 98/2000/XP**
- **Microsoft .NET Framework V1.1** and **Microsoft Internet Explorer 5.01**
- **Microsoft Managed DirectX9** or a later version for the joystick
- Pentium 400MHZ Processor or better (or equivalent hardware)
- Disc station CD-ROM
- RAM 64 MB
- Hard disc 40MB free
- USB Port
- Controller **EAS USB Controller**

The NC-EAS(Y) program is based on the latest Microsoft .NET technology and it requires the Microsoft .NET Framework V1.1. Microsoft .NET Framework is free of charge and may be downloaded from the Microsoft websites.

2.3 Installation

The NC-EAS(Y) program may be downloaded from our website. On your request we may supply you with the CD-ROM version of NC-EAS(Y). The CD-ROM also contains Microsoft Framework V1.1. To install the NC-EAS(Y) program you need to perform the following operations:

1. Install **Microsoft .NET Framework V1.1** by calling up the dotnetfx.exe file. The Microsoft installation program will take you through the installation procedure in a step-by-step manner. In the event that Microsoft .NET V1.1 was already installed earlier or if you are a user of Windows XP with Service Pack 1, you may skip this stage of installation.
2. Install the NC-EAS(Y) program by starting the **setupxxx.exe** file. The NC-EAS(Y) installation program will take you through the installation procedure in a step-by-step manner.
3. To control the CNC milling machine with the use of the joystick it is essential to install Microsoft Managed DirectX9 or its later version. To install Microsoft Managed DirectX9 call up the installation file **dxsetup.exe** with the '/installmanageddx' parameter.

Example: **CD-ROM:DirectX\dxsetup /installmanageddx**

To drive and control the stepper motors via the NC-EAS(Y) program, the **EAS USB Controller** controller is essential.

Very important: In order not to interrupt the work of the CNC milling machine, Power Management must be turned off in BIOS. Please also check the power management in the options of the Windows management panel.

Installation of the EAS USB Controller drive

First install the NC-EAS(Y) program and then connect the USB cable (turn on the electronics). This is in order to ensure that the USB drive has been copied onto the hard disc. Further information has been included in the file **install-en.pdf**.

2.4 EAS USB Controller

The EAS USB Controller controller generates the heartbeat and direction signals for 4 stepper motors. The maximum clock frequency equals 42kHz for the interpolation moves on 4 axes. Through the inputs the reference connectors / pins may be read: start, stop, and other signals. Additional outputs may be used for performing such operations as: turn on/off the pump, limit the motor current, turn on/off the drill spindle motor and regulate its rotation. Organisation of signal flow on the controller output connection has been adopted from the NC-EAS(Y) version for DOS system.

The controller is based on PLD (programmable logic device). The 12MHz quartz oscillator and the 64 kByte of data memory ensure a stable impulse transmission. Quick data exchange with the computer is performed via the **USB 1.1 port**. Power supply for the system may be performed from the source of port USB 1.1. or through a flat cable connection of 5 V stabilised voltage to the MOST3/4A driver for stepper motors.

2.5 Starting up the NC-EAS(Y) program

Once the program is installed, NC-EAS(Y) may be started up by clicking the icon on the desktop or by clicking the Start menu -> Programs key. NC-EAS(Y) may be started up only once. At the start up it is possible to quote a file along with a catalogue, which shall be opened automatically.

Example: **cnc.exe c:\directory\file.plt**

During the first start-up, the NC-EAS(Y) program does not have any configuration setup and the basic configuration is being established. Before you can do any actual work on the *CNC* machine, specific machine parameters must be determined this only once, in the main menu "Settings -> Machine parameters -> Adjust .." Optionally, it is possible to download the specific machine parameters from the main menu "Setup -> Machine parameters -> Open..".

All the machine parameters have been described in detail in the "[Settings](#)¹⁸" chapter.

Hint: Each time the NC-EAS(Y) program is started up a so-called "[reference move](#)³⁵" must be performed. This operation makes it possible to determine the ZERO point, which means that from this moment on the program is able to recognise where the point of coordinates 0,0,0 is. Without this operation the program will not recognise the position of each of the machine axes.

3 Menu

In order to make the implementation and usage easier, the NC-EAS(Y) program has been equipped with an innovative, graphically designed interface, which is much similar to the standard WINDOWS® applications.

3.1 Horizontal and vertical toolbars

The most crucial functions are equipped with their relative icons on the horizontal and vertical toolbars, and shortcut keys.



Illustration 1: The vertical toolbar has all the drawing functions.

The vertical toolbar has the following drawing functions (from top to bottom):

- Change of tool number and the direction of milling
- Locate on work-piece/material or the machine area
- Copying the vectors, drill points or their parts
- Rotating the vectors or drill points
- Mirror reflection according to X-axis Y-axis
- Expanding the drawing on the work-piece/material or the machine area



Illustration 2: The horizontal toolbar is divided into sectors.

The horizontal toolbar is divided into the following sectors (from left to right):

- The **data sector** includes the following functions: Open new file, Open file, Save file, Undo, Repeat, Selection Window (choice between vectors, drill points or all)
- The **view sector** includes the following functions: Display machine area, Display work-piece/material, Display drawing, Expand with the window, Expand or diminish the drawing
- The **setup sector** includes the following functions: Unit, Toolbox, Machine parameters, Material parameters, Positions, and Quick setting of point zero.
- The **moves sector** includes functions which govern the movements of the CNC milling machine. These functions are: Mill/Drill, Stop the CNC milling machine, Pause in the work of the CNC milling machine, Scan area of material height, Reference move, and Manual advance.

Hint: The toolbars may be turned on or off in the main menu. "View -> Toolbars".

3.2 Main menu "Pulldown" bar

The "Pulldown" main menu bar includes all the functions except "Selection Window" and "Unit". The "Pulldown" main menu bar consists of the following options:

File Edit View Move Settings Help

Illustration: "Pulldown" main menu

1. The **File** menu includes functions which concern file processing / editing. Some functions at your disposal here are: "open file", "close the opened file", "open text editor". Detailed information on the topic of files has been included in the "data" chapter.
2. The **Edit** menu includes functions which concern the processing of entered data. A drawing may be altered here or the Tangential cutter correction may be calculated. Detailed information on the topic of data processing has been included in chapter entitled "Data editing"
3. The **View** menu includes functions which change the size of the loaded drawing. Detailed information on the topic of viewing data has been included in the chapter entitled "The Zoom function"
4. The **Move** menu includes functions which advance the CNC milling machine. Some of the functions are: "Simulation", "Job", "Material height scan" or "Machine manual advance". Detailed information on the topic of advancing the CNC machine has been included in chapter entitled "Move"
5. The **Setup** menu includes all the functions concerning the setup of the CNC milling machine and the NC-EAS(Y) program. The particularly important function is "Machine parameters" which must be set well so that the CNC machine operates accordingly. Detailed information has been included in the "Settings" chapter.
6. The **Help** menu is equipped with a user's manual and information on the topic of NC-EAS(Y).

3.3 The status bars

The NC-EAS(Y) program is equipped with three status bars which provide the user with the following information:

- Both upper status bars indicate the current position of the CNC milling machine. The position is displayed in absolute and relative coordinates in millimetres. Relative coordinates may be deleted in the "View" dialogue window or directly on the status bar by pressing the key of a particular relative coordinate.

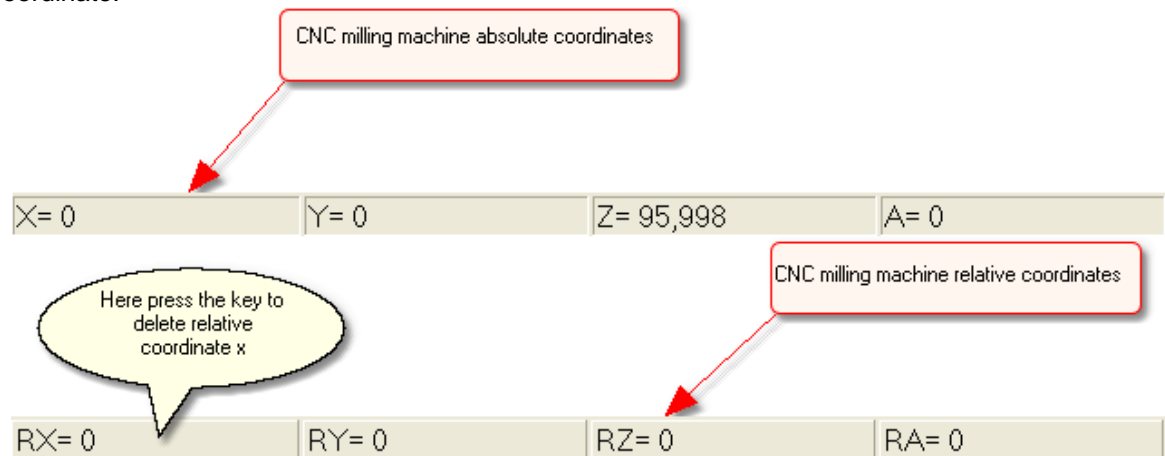

Illustration 1: The upper status bars with relative and absolute coordinates of the CNC machine.

- The bottom status bar indicates the mouse coordinates, the unit, and provides information related to the CNC milling machine's work (amount of work performed in %, tool number, speed of manual drive,...)

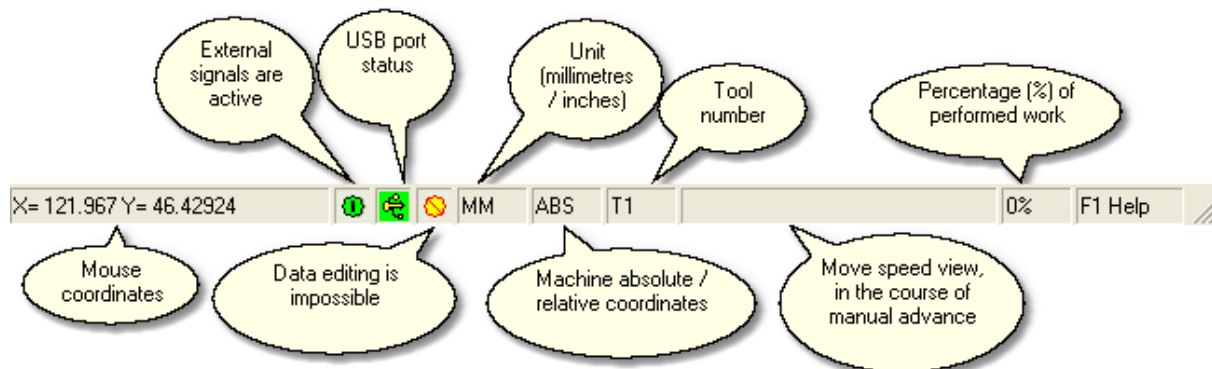

Illustration 2: The bottom status bar

Hint: The status bars may be turned on or off in the main menu "View -> Toolbars".

3.4 The coordinate system

The machine coordinate system corresponds to the Cartesian coordinate system. The starting point of the X and Y axes is located in the left bottom corner. Once a Reference Move is performed, the counters for the machine absolute coordinates for axes X and Y are set to value 0 (zero), whereas for axis Z the before set length of axis Z.

Note: When the Z-axis is moved downward, the value of the Z axis counter diminishes!

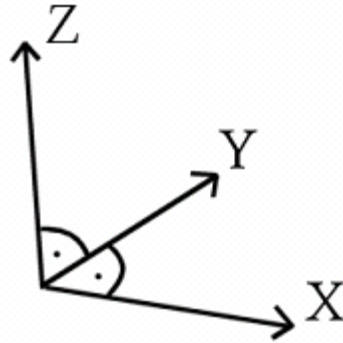

Illustration: The coordinate system

The mouse coordinate system

The left bottom corner of the screen displays the mouse coordinates. These co-ordinates may either be displayed in centimetres or in inches. Additionally, it is possible to switch to and from the absolute and relative values. The relative values have their origin in the zero point of the material, whereas the absolute values in the zero point of the machine. The icon for switching between the absolute-relative values and the centimetre-inch values is located on the horizontal tool bar.

Description	Key	Menu command	Icon
Switching between the absolute and relative values and cm/inches	none	none	

3.5 Interface

The USB port in a PC computer includes input and output drives. The input is used for reading the signals sent by the machine e.g. by the limit switches. The computer, on the other hand, sends, through the output drives, signals which control the machine. Clicking the mouse left key on a proper area changes its active level to the opposite level. Clicking the mouse on input 1 switches on or off the cutter / fraise drive.

<i>Description</i>	<i>Key</i>	<i>Menu command</i>	<i>Icon</i>
Dialogue window " Interface" enables control over the USB port input and output drives	[Ctrl + I]	View • Interface	none

4 Data files

The NC-EAS(Y) program makes it possible to import various data file-formats: HPGL, DIN 66025, Excellon, Sieb & Maier 1000 and Sieb & Maier 3000. The read data files can be altered in size by scaling or changing the scale.

4.1 Working on the data

The "**Open / Insert**" dialogue window makes it possible to enter new or insert / load other data to the files currently open. Both windows are the standard dialogue windows for the Windows system.

Open file

In order to open a data file, click on icon  on the horizontal toolbar. Alternatively, a data file may be opened in the main menu of the NC-EAS(Y) program or by pressing a shortcut key.

Description	Key	Menu command	Icon
Open file	[Ctrl +O]	File • Open	
Choosing 1 of the 4 recently retrieved files	none	File • 1 to 4	none

In the "**Open**" dialogue window the following types of files may be chosen:

- HPGL(*.plt)
- DIN 66035(*.nc)
- Sieb & Maier(*.drl), Excellon, SM1000, SM3000
- NC-EAS(Y)(* .grf)
- all NC files(*.*)

When choosing a type of file without a file extension (*.*), this type of file shall be recognised automatically.

Hint: In the event that the type of file could not be recognised automatically, the following information appears:

"File ,c:\example.nc' is of unknown format. Do you wish to quote the file type and try again?"

For the file to be loaded anyway, the file type must be entered in the successive attempt to load the file.

Insert file

Once a data file is opened, it is possible to insert into it a drawing from an outside file. The procedure is identical here as in the case of opening a file.

Description	Key	Menu command	Icon
Insert data	none	File • Insert	none

In the "**Insert**" dialogue window the following types of files may be chosen:

- HPGL(*.plt)
- Sieb & Maier(*.drl), Excellon, SM1000, SM3000

Once the unit and the scale of the drawing are selected, the "Location choice" dialogue window appears which makes it possible to define the location of the inserted file.

Browse with the aid of the view window

With the use of the "**Browse**" function it is possible to view the files in the view window before they are loaded. A file is loaded with a double click of the left mouse button. All the loaded files are automatically added to the "**Favourite**" list which then makes it easy to find a particular file and load it again.

Description	Key	Menu command	Icon
Search with the use of the view window	none	File • Search	

Hint: In the course of opening the files the settings defined in the "[File formats](#)"^[29] dialogue window are applied.

4.2 Interpreter HPGL

Hewlett Packard Graphics Language, HPGL in short, is a data format generated or exported by almost all CAD-programs. The NC-EAS(Y) program interprets the following HPGL commands:

HPGL functions

- PU** - Tool up
- PD** - Tool down
- PA** - Further move to positions with latest definitions
- PR** - Move to relative position
- SPx** - Tool number
- AA** - Absolute arc
- AR** - Relative arc
- CI** - Circle

<i>Example</i>	
<i>HPGL</i>	<i>Description of commands</i>
PU;	Tool up
PA100, 50;	Move to the absolute position, X=100, Y=50
PR100, 50;	Move to relative position, so that the new absolute position is: X200,Y100
PD;	Tool down
CI100;	Circle radius equal 100 counter-clockwise, (for radius -100 clockwise),
AA300, 200, 50;	Draws a 50-degree-radius arc with its centre at point X300,Y200 and the starting point at 100,50
SP1;	Tool choice (here tool no.1)

4.3 Drill data interpreter

The NC-EAS(Y) program recognizes the following drill data formats: Excellon, Sieb&Maier 1000 and Sieb&Maier 3000. Two examples have been provided below:

<i>Sieb & Maier</i>		<i>Description of commands</i>
<i>Example 1</i>	<i>Example 2</i>	
% T01	% T01	T01 Tool no. 1 has been selected
X001Y0001	X100Y10	Move to positions X100, Y10 and the tool immerses in the material
M30	M30	M30 end of program

There are two types of drill data at your disposal. The first format (see example 1): the coordinates are always 5-digit ones. This is why they have the leading zeroes. The back zeroes are frequently skipped. The second format (see example 2) has no leading zeroes and the numbers are of varied length. The "[File formats](#)"²⁹ dialogue window makes it possible to set the type of drill data.

4.4 Interpreter DIN 66025

The standardized data file-format DIN 66025 is the standard applied in professional CNC 2½ and 3D machines.

Hint: The Din 66025 type files may not be edited. Only copying, moving and scaling is possible.

The NC-EAS(Y) program interprets the following commands:

G-Codes:

G00	Rapid advance
G01	Working speed advance
G02	Circle (Arc) clockwise movement
G03	Circle (Arc) counter-clockwise movement
G04	Pause
G70	Unit in inches
G71	Unit in millimetres
G90	Absolute mode
G91	Relative mode

M-Codes:

M03	Turn on the power feed of the tool
M05	Turn off the power feed
M08	Turn on the coolant pump
M09	Turn off the coolant pump
M30	End of program

Other CNC commands

F	Advance rate mm/min
N	Task number
T	Tool number

The **G00** command moves the tool with the maximum speed rate of the milling machine. The tool is positioned above the material.

<i>Example 1</i>	
<i>DIN 66025</i>	<i>Description of commands</i>
N01 G00 X0 Y0 Z10 N02 M3 M8	Moves the tool to point X0, Y0, and Z10 M3 turns on the drill spindle M8 turns on the coolant pump
N03 G01 Z-2 F50	The tool penetrates the material 2mm deep with the speed of 50 mm/min.
N04 G01 X100 Y100 F100	Moves the tool at advance seed rate of 100 mm/min. to point X100 and Y100
N05 G00 Z10 M5 M9	Moves the tool to position Z10 M5 turns off the drill spindle M9 turns off the coolant pump
N06 M30	End of program.

The **G02** command moves the tool along the arc in a clockwise manner, whereas **G03** moves the tool counter-clockwise. The starting point of the arc is in the current tool position. The end of the arc is

determined in commands G2(G3) with the use of commands X,Y and Z, which stand for, respectively, the coordinates for axes X, Y and Z. Commands J and I determine the centre of the circle. Please find below the control commands for the G2(3) instructions:

X End coordinates in axis X
Y End coordinates in axis Y
I Circle centre in axis X
J Circle centre in axis Y
K Circle centre in axis Z

Example 2	
DIN 66025	Description of commands
N01 G00 X0 Y0 Z10 N02 M3	Moves the tool to position X0, Y0 and Z10 M3 turns on the drill spindle
N03 G01 X10 Y10 F100 N04 G01 Z-2 F50	Moves the tool at the speed rate of 100 mm/min. to position X10, Y10 The tool penetrates the material 2mm deep with the speed of 50 mm/min.
N05 G02 I20 J10 X30 Y10 N07 G00 Z10 N08 M30	Moves the tool along the arc with the arc centre at point I20, J10, from point X10, Y10 to X30, Y10 Lifts up the tool by 10 mm M30 End of program

Example 3 illustrates the making of a screw thread (2mm pitch of thread 6 mm long) – 3 coils/convolutions. When making a full circle, the starting point corresponds to the ending point.

Example 3
N01 G0 X500 Y500 N02 G0 Z-5 N03 G2 I550 J500 Z-7 F60 N04 G2 I550 J500 Z-9 N05 G2 I550 J500 Z-11 N06 G0 Z0

The **G04** command enables a delay to be programmed. **G04 H2** denotes a 2-second delay. This function is used, for example, to allow time for the drill spindle to gather speed.

Example 4	
DIN 66025	Description of commands
N10 G04 H2.5	The tool stops for 2.5 seconds (the drill spindle continues rotating)

The **G90** command sets the coordinate system at the absolute values.

Example 5	
DIN 66025	Description of commands

N08 G90	Absolute coordinates
N09 G01 X100 Y100	Moves the tool to position X100, Y100
N10 G91	G91 switches on the relative
N11 G01 X10	coordinates
N12 G01 X5 Y-5	Moves the tool to position X110, Y100
	Moves the tool to position X115, Y95

The list of control commands may be created under any freely chosen text editor. Small letters may be used but the command code must not contain any blank spaces. It is not obligatory to number the instructions and so numbering may be skipped.

4.5 Interpreter GRF

The GRF format is the format of the NC-EAS(Y) program and it saves in the file all the changes made by the NC-EAS(Y). The GRF format includes the following information:







- Vectors and drill points
- Tools for vectors and drill points
- Unit and drawing scaling (for file DIN 66025 only scaling)
- Material offset and the zero point of the material

When opening the GRF file, NC-EAS(Y) checks whether the zero point in the GRF format is used. If the zero point is not used, the user is presented with a request to check the offset of the material.

4.6 The zoom functions

The size of the drawing can be increased or reduced at any time. In order to achieve this aim you can choose from several options. For instance: you can use the mouse to click on the Zoom icon or press the key 1 or 0. The "Zoom window" function makes it possible to enlarge / expand the fragment indicated with the mouse (a rectangle section). The "Pan" function moves the drawing without changing its size.

All the zoom-functions have been listed in the table below.

Description	Key	Menu command	Icon
Zoom a selected area	none	View • Zoom window	
Enlarging the drawing	none	none	
Diminishing the drawing	none	none	
Display the drawing	[F4]	View • Display drawing	
Display the machine area	[F3]	View • Display machine area	
Display the material	[F2]	View • Display material	
Zoom in / out	[1 or 2] + mouse position, or mouse with scroll	none	none
New drawing	[Ctrl + R]	View • Refresh	none
Move the drawing (Pan)	Mouse position + mouse right key + Pan	none	none
Vertical and horizontal drawing-move bar (Pan)	Mouse left key on the drawing move-bar	none	none



5 Settings

In order for the NC-EAS(Y) program to control the stepper motors, the CNC milling machine parameters and the NC-EAS(Y) program parameters must be set and adjusted accordingly.

5.1 Machine parameters

Once the program is installed, it is required to determine what the parameters of the CNC machine are; the CNC machine is referred to here as the "machine". The parameters must be determined correctly as their wrong introduction may hamper the operation of the machine and may even lead to the damage of the processed material, the milling cutter / the drill or the milling machine.

To enable a quick change in the parameters for various types of machines, the machine parameters may be entered into a file or a machine parameter file may be opened.

<i>Description</i>	<i>Key</i>	<i>Menu command</i>	<i>Icon</i>
Opening a dialogue window with machine parameters	[F8]	Settings • Machine parameters • Adjust	
Opening a file with machine parameters	none	Settings • Machine parameters • Open	
Saving machine parameters in a file	none	Settings • Machine parameters • Save	

All the CNC milling machine parameters are saved in the NC-EAS(Y) in the "machine" directory in an XML file type. The dialogue window "**Machine parameters**" is organised in the following manner:

[Code](#) ¹⁹
[Axes](#) ¹⁹
 [Axis of rotation](#) ¹⁹
 [Tangent axis](#) ²⁰
 [Backlash elimination](#) ²⁰
[Pin parameters \(Port A\)](#) ²¹
 [Input signals \(Port A-B\)](#) ²²
[Speed](#) ²²
[Automatic tool change](#) ²²
[Height scan sensor](#) ²³

The "OK" and "Apply" keys

Any changes made in the "Machine parameters" dialogue window are saved by pressing the "OK" or the "Apply" keys. The "Apply" key does not close the dialogue window and the introduced changes are applied right away without opening and closing the dialogue window.

5.1.1 Code

When the machine parameters are set, it is sometimes worthwhile to protect them from inexperienced users. The introduction of a code makes it impossible for unauthorized users to gain access to the "Machine parameters" dialogue window. Similarly, it is then impossible for others to save CNC machine parameters. To turn off the code it is necessary to enter the current code into the "old code" option leaving other options blank.

Hint: As help in case the code is forgotten, it is possible to enter a tip (word or sentence) concerning the code.

5.1.2 Axes

NC-EAS(Y) may control up to 4 axes. Additionally, it is possible to control axis X with a double drive. The following settings are available:

- The **length of axis Z** is assumed to equal its permissible scope of revolution. On the screen, the scope of revolution of axis X and Y is shown as a white sheet.
- To define the **axis resolution**, for each axis the number of steps per rotation and the rotation path must be quoted. Initially, the axis resolution is calculated automatically in millimetres per step and is presented in a box below.
- **Connector A** switches on or off the fourth axis. When the fourth axis is switched off, it is not possible to use the axis of rotation or the [tangent axis](#) ^[20] as axis four. Axis A is available in the controller versions from V2.0 to EAS USB Controller.
- [Axis of rotation](#) ^[19] may work with a 4-axes driver as well as, with certain inconveniences, with a 3-axes driver.

5.1.2.1 Axis of rotation

Depending on the number of axes of the steering electronics, two work modes are possible:

4-axes driver

The machine parameters allow the axis of rotation to be defined as the fourth axis once the axis A switch has been activated. The axis of rotation may be installed on the milling table in the direction of axis X or axis Y. Selecting an adequate direction: direction or direction results in directing the coordinates of a selected axis to the axis of rotation.

If the scratch file has coordinates for all 4 axes (processing in four dimensions), then the selection of direction X or Y serves merely the purpose of displaying the axis position on the screen. The reference move to the limit switches and positioning may take place on 4 axes.

3-axes driver

With a 3-axes driver, axis A must be inactive (the switch A is turned off). The axis of rotation is connected to the driver (output X or Y) through a change / swap of plugs.

Symbolic presentation of the axis of rotation on the screen

Once the axis of rotation is switched on in the menu "Machine parameters-> Axes -> Axis of rotation", the length line shall appear on the screen $U=D \times P$, where D is the diameter of the material. Another line runs from the onset of the length line and perpendicularly to it, a line which corresponds to the axis of rotation. The third dashed line outlines the material area.

Positioning the axis of rotation

Once a device with the axis of rotation is installed on the milling table, its position must be entered into the program.

1. Before switching on the axis of rotation in menu "Machine parameters -> Axes -> Axis of rotation", perform a reference move.
2. Fix the material to the rotation axis handle.

3. Using the manual advance locate the device blade on the onset of material and over its axis of rotation.
4. Save the position in menu "Location" under the name "Axis of rotation".
5. Switch on the rotation axis in menu "Machine parameters -> Axes -> Axis of rotation". Lines will appear on the screen symbolizing the axis of rotation with a direction adjusted to a selected axis (X or Y).
6. When using a 3-axes driver it is now possible to plug in the axis of rotation in place of a selected axis (X or Y).

5.1.2.2 Tangent axis

For cutting thick foil or cardboard a Tangential cutter is used. The Tangential cutter is set, with the use of stepper motors, in the direction of material cutting. The applied cutter must be double-edged with the blade in the axis of rotation. For the drive of a stepper motor a 4-axes driver is necessary. Once the 4 axis is activated with a switch A , the function of the tangential cutter is available.

Steps/turn is the number of stepper motor steps per one full turn. **Raise from the angle** is the angle in degrees between the subsequent segments (vectors) within the scope of which the cutter remains in the material in the course of its rotation, in agreement with the direction of move. Over this angle the cutter is removed from the material, turned in the new segment cutting direction and is again immersed into the material. To avoid damage to the material, the value of this angle should not exceed 45 degrees.

5.1.2.3 Backlash

Backlash is undesirable play between the spindle and the cap or between the pinion and the toothed bar of the power drive. The play is generated in the course of a change in move direction. This function cancels the play. Backlash is entered for axis x, y and axis z in millimetres or in steps.

Hint: The "Backlash elimination" function is applied only in the course of milling / drilling.

5.1.3 PIN parameters (Port A)

It is essential to correlate the move directions, input and output, and so they must be adjusted. The following settings are available:

- **Reference connectors** may be inverted manually or with the aid of the PIN reference assistant.

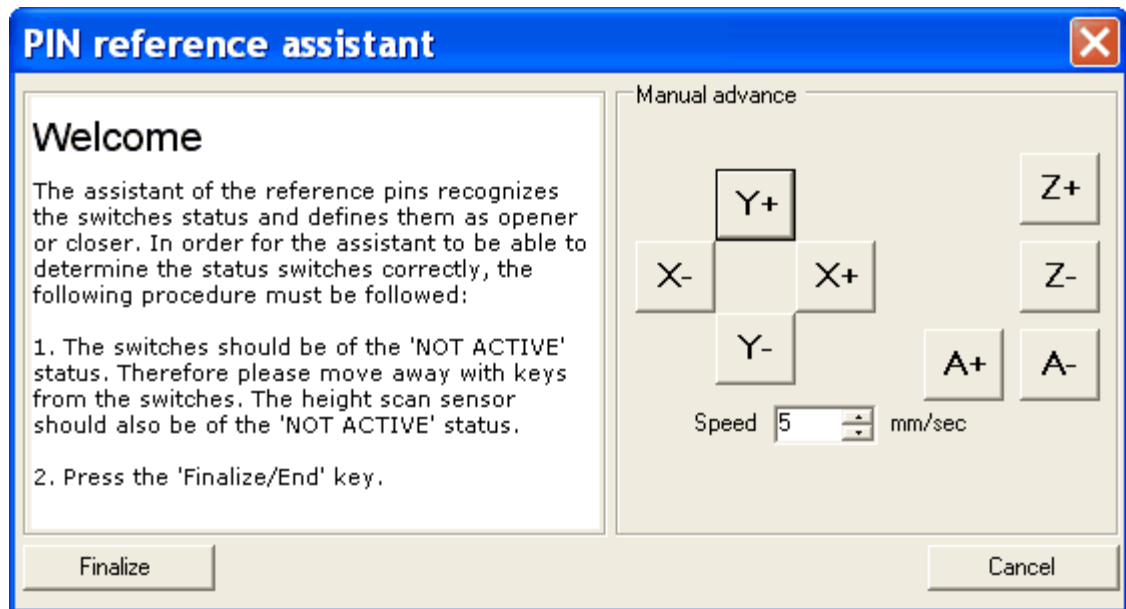

Illustration: PIN reference assistant

- In the course of the Reference Move, first the Z axis moves upwards until the limit switch switches into operation, and next the axes X, Y and A perform the same operation in a set **reference move sequence**. Once all the axes reach the limit switches, they then move slowly in the opposite direction until the switches are disconnected. The counters for axes X, Y and A reach the zero value, whereas axis Z is set at the length of this axis.
- **The move direction and reference move direction** may, if needed, be changed. The correctness of a set direction may be checked in case of manual advance. Axis X moves forward when pressing the cursor-key Ⓢ. The - key moves the Y axis forward, whereas the $\bar{\text{~}}$ key moves the Z axis downwards (that is in the negative direction).
- It is advisable to limit the motor current as it protects the driving motors against overheating in the course of a lengthy inactivity.
- Controller EAS USB Controller has **input** drives 1,2,3 and 6 for the **reference move**. Depending on the cables, connectors X, Y, A and Z may be freely assigned to the reference input drives.
- The hood connector controls the hood in the course of milling. If the hood is raised in the course of milling, then milling is stopped and the "Raised hood" report appears.
- Sometimes the output drives are distorted and they function the other way round. In this case such output drives must be inverted. The **spindle, pump, motor current** and the **fixing clamps** may be inverted. Output may also be adjusted for the pump, spindle and the fixing clamps.

5.1.3.1 Input signals (Port A-B)

There are further 9 inputs on the side of the EAS USB Controller controller. These are for the following external signals:

- **Start the machine**
- **Pause**, the machine has been stopped
- **Start the reference** move
- The **hood** has been opened. If the hood has been opened in the course of milling or the reference move, then the work of CNC milling machine is stopped immediately and the message "Hood is open" appears.

Hint: The external signal must be ticked in order to be activated.

5.1.4 Speed

The speed must be adjusted accordingly to the type of the CNC milling machine. Too high speed may result in a loss of step. The following parameters are available:

- The **maximum speed** parameter determining the maximum permissible speed, at which the machine operates appropriately and skips no steps.
- **Reference speed** is the speed of axes X, Y and Z in the course of performing the Reference Move.
- The **Start/Stop speed** prevents step skipping in the course of accelerating or stopping the motors. The value of this parameter must not be too high.
- The constant **working speed** is also constant in the course of interpolation moves.
- **Acceleration rate** may be low, average, high or extremely high.
- **Move speed to a scan / measurement point** is the speed of axis Z in the course of a move to the height scan point. Once the height scan is performed, axis Z is raised at the Start/Stop speed.

5.1.5 Automatic tool change

The automatic tool change option has control over the machine / device and may have up to 33 tools. To use the automatic tool change option the following operations must be performed:

- The **Properties** define the general setup for the automatic tool change. The first thing to do is to switch on this option by pressing the connector. **Waiting time** is the time when the opened spindle is waiting and subsequently either picks a new tool or puts away the old tool. Once the tool position is arrived at, an immersion is made on axis Z with the entered **speed and segment**. Connector allows to count the tools from number 0. Finally, the colour of the empty of full space in the device may be given.
- Next the **position** X, Y and Z of the first tool must be given.
- The **Offset** list defines positions of the next tools (maximum up to 32). The offset is the distance of axis X and Y to the last tool. Particular tools may be switched off by clicking a box on the list. Tools switched off are not displayed graphically.

5.1.6 Height sensor

The height sensor measures the height of the material surface. With the backup of data, the measured material surface, NC-EAS(Y) corrects the height of the drill spindle (axis Z) in the course of milling. A further possibility is the export of material height data to DXF format (as lines or points) or to format Din66025. For the height sensor to work appropriately, the distance (offset) in X and Y between the height sensor and the tool tip (see: illustration) must be measured **carefully and accurately**.

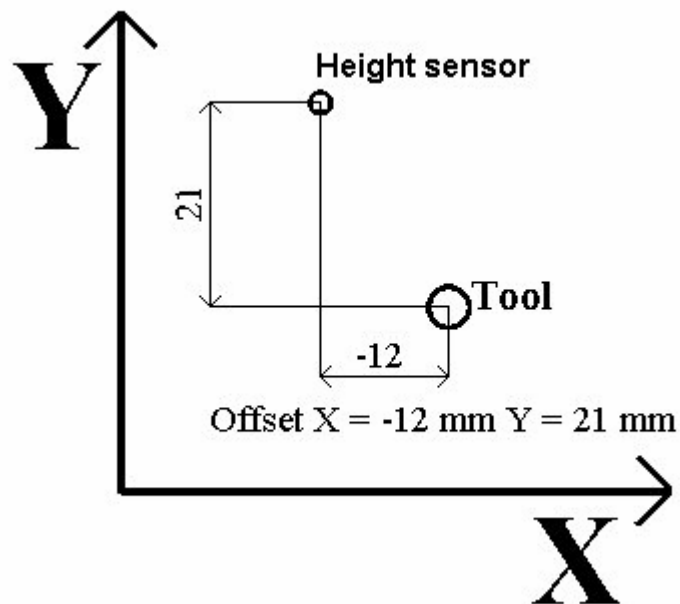

Illustration: Distance between the height sensor and the tool

How to calculate the distance between the height sensor and the tool (Offset):



1. Move the machine to **Point Zero** of the material and carefully and accurately mark this position on the material e.g. by scratching the surface with the tip of the milling cutter.
2. Change the machine coordinates to **Relative** and make a note of them.
3. Locate the tip of the height sensor precisely above the marked point.
4. Choose the "**Machine parameters**" option from the menu and enter the previously noted coordinates into the Offset area/box

5.2 Positions

In order to perform a move to the park point or the measurement point, the points must first be defined in the "Position" dialogue window. This window may be opened through the main menu of the program or the "Manual advance" dialogue window.

Description	Key	Menu command	Icon
Position setting	[Ctrl +P]	Settings • Position (in the program main menu) or Settings • Zero point/Park point/Measurement Point (in the "Manual advance" dialogue menu)	

Here any number of zero points, park points and measurement points may be defined, however only one of each of the point types may have the "in use" status. For this reason only (maximally) one zero

point , one park point , and one measurement point  is graphically displayed in the drawing.

Selection of zero point, park point and measurement point

By choosing a relevant tab the type of position for the purpose of processing is selected and a list of such positions appears.

Status	Name	X	Y	Z	A	Material thickness
	alu	290.649	97.809	74.462	0	66.08
	name	30	31	74.074	0	65.692
	test	20	0	100	0	91.618
	NameXXXX	10	5	34	0	25.618

Illustration: Tag selected for zero points

Insert positions

By clicking the "Add" option, the "Add positions" dialogue window appears. Here the parameters of a new point (X-, Y-, Z-, A- coordinates, status and name of point) are entered. By clicking "Insert" the current machine coordinates are entered into the input fields. Height may be defined by entering the material thickness data. In order to enter the material thickness data, calibration of the tool-length sensor must be performed once.

Change positions

First you need to select a point, that you wish to change, from the list. Then it is possible to change the properties of the selected point directly by clicking on the column in the table of a particular point value. Also by selecting "Insert positions" you may enter the current coordinates of the CNC milling machine by clicking "Insert".

Delete positions

In order to delete a location from the list, first the selected location must be entered and then the "Delete" key must be pressed.

Changing the properties of positions

These properties define the performance of zero points, scan points and park points. A move to a particular point may be performed directly or in a defined sequence of axes. The "Display confirmation" option turns on or off the dialogue window which appears prior to a move to a point. A move to the zero point may be performed automatically after the reference move.

5.3 Material offset

The material offset is the distance between the point at which the tool is fixed and the material zero point (see: Illustration 4). In the GRF format of the NC-EAS(Y) program the material offset and the material zero point are recorded. Material zero point is recorded in the GRF format only for control purposes while opening this file. In the event that the material zero point of the entered drawing does not correspond to the currently active material point, the following information is displayed:

„NC-EAS(Y) has no zero point for the particular the drawing! Please check the material offset.“

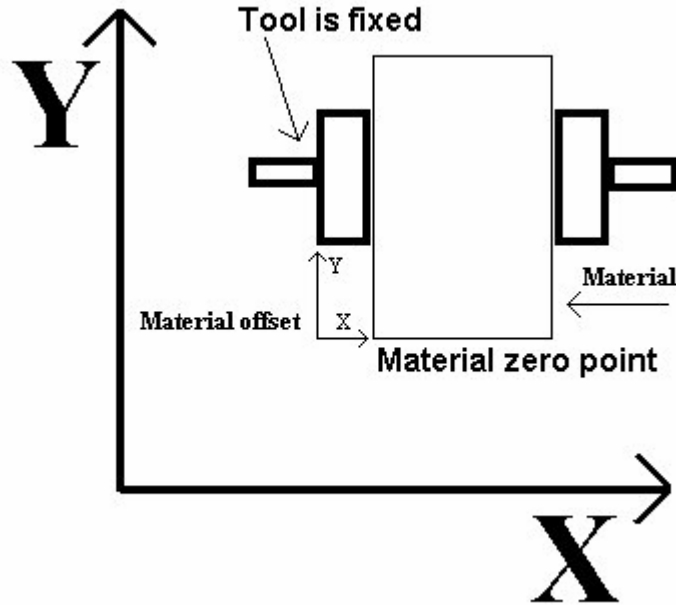

Illustration: Material offset.

Hint: If the zero point of the material has changed, there is no need to change all the GRF type files but just the material offset in the opened GRF file.

The menu of the "Manual advance" dialogue window makes it possible to define the material offset manually by entering the data with the use of the keyboard or by moving the machine to a given point.

Description	Key	Menu command	Icon
Material offset in X and Y is entered from the current machine position	none	Edit (in the "Manual advance" dialogue window) • Insert offset • XY	none
Material offset in X, Y and Z is entered from the current machine position	none	Edit (in the "Manual advance" dialogue window) • Insert offset • XYZ	none
Material offset in X is entered from the current machine position	none	Edit (in the "Manual advance" dialogue window) • Insert offset • X	none
Material offset in Y is entered from the current machine position	none	Edit (in the "Manual advance" dialogue window) • Insert offset • Y	none

Material offset in Z is entered from the current machine position	none	Edit (in the "Manual advance" dialogue window) • Insert offset • Z	none
Manual entry of material offset data	none	Edit (in the "Manual advance" dialogue window) • Insert offset • Manual data entry	none

5.4 Material parameters

For the purpose of visual control, the size of the processed material may be graphically displayed on the screen.

Description	Key	Menu command	Icon
Opens the "Material parameters" dialogue window	none	Settings • Material parameters	

In direction X and Y the defined **material size** (in millimetres) may be displayed in a freely chosen colour. From the list of existing zero points a new zero point may be selected.

Hint: If a new point is needed, it must be defined in the "[Position](#)"^[24] dialogue window.

5.5 Toolbox

The "Toolbox" dialogue window controls the two lists of tools for the vectors (for HPGL and optionally for DIN 66025 – see chapter: "[File formats](#)"^[29]) and the drill points (Sieb & Maier). Each list may manage up to 100 tools and offers such properties as, for example, working speed, speed of pulling out the tool, depth of penetration, diameter, etc. These properties are used in the process of milling, drilling or at calculating the tool correction. The column "Active/No." enables the switching on and off of particular tools. Switched off tools are not displayed in the drawing and are not used for milling and drilling.

Description	Key	Menu command	Icon
Opens the "Toolbox" dialogue window	[Ctrl + T]	Settings • Toolbox	

Depending on the depth of immersion and the type of tool, the diameter of the milled surface changes. As help for the calculation of the diameter the "**Calculate diameter**" dialogue window may be used by clicking the key  beside the diameter box. Calculation of the tool diameter is possible only for the milling cutter. The diameter is necessary for [tool diameter correction](#)^[42].

Hint: The "Display tools in use" function limits the tool overview to the tools currently in use.

5.6 Macros

In the "Macros" dialogue window it is possible to define operation sequences, operations that may be part of the milling or drilling process and that could be called up at any given point. This way the performance of various tasks may be automated. Each operation sequence, here called a macro, is saved under a file name. The "Macros" dialogue window displays a list of all the program macros.

Description	Key	Menu command	Icon
Macro – process	none	Settings • Macros	none

Saving and changing a macro

Upon clicking the "New" option in the "Macros" dialogue window, the "Macro save" dialogue window

appears where a new macro is defined. If an existing macro is to be changed, then it must be selected from the list displayed in the "Macros" dialogue window and the option "Edit" must be selected.

The "Macro save" dialogue window consists of two sections:

1. The "Macro" section includes a list with the commands of a given macro. The macro is performed according to this list, from top to bottom. The list consists of a sequence and all the parts of the sequence are performed. The sequence may be changed by pressing the arrow function keys. Single sequences are cancelled by pressing the "Delete" key. A new sequence may be set up or changed in the "Command" section.

2. The "Command" section allows for the addition of a new task to a particular macro or for changes to the tasks existing already. The following commands are available:

- With the use of the **absolute vector** a move to a chosen X, Y, Z and A point is performed. The speed of the move is entered manually or by quoting the maximum speed of the machine.
- **Waiting time** stops the machine for a given time in milliseconds.
- With the use of a **connector** the drill spindle and the pump are turned on or off.

Saving a macro

Once a macro is established it must be saved in a file. All macros are saved in the "Macros" catalogue in files supplied with the .macro extension. To save a macro the "Save" option must be clicked in the "Macro save" dialogue window.

Exporting macros

Macros may be exported for further editing in format Din 66025. To export a macro you need to select a particular macro from the list and click the "export" key.

Testing a macro and applying it to / inserting into Milling/Drilling

Before a macro is applied in the "Milling/Drilling" operation it should be checked first. The "Perform macro" dialogue window enables the application of particular macros through the selection of a particular macro from the list and clicking the "Start" option.

Description	Key	Menu command	Icon
Single macro performance	none	Move • Macro	none
Editing, apply/insert macro	[F9]	Move • Milling/drilling	▶

Any macros for the operation of "Milling/drilling" may be entered into the "Work parameters" dialogue window. The first thing to do is to activate a macro in the "Macro" section. Then a particular macro must be selected from the list of macros and the place for its application must be defined. Here various possibilities apply:

- Perform macro at the beginning of work
- Perform macro at the end of work
- Perform macro after processing (the "Repeat processing" function)
- Perform macro after tool change

Upon selecting a macro and defining the location for the performance of a given macro, the particular macro must be added to the performance list with the '->' key. With the use of the '<-' key the macro is removed from the performance list.

5.7 Options

The "*Options*" dialogue window includes all the settings of the graphical editor of the NC-EAS(Y) program. These settings have been grouped into "*General*", "*View*", "*Performance*" and "*Editor*" tabs.

Description	Key	Menu command	Icon
General settings of the graphic editor	none	Settings • Options	none

General

The **Scratch catalogue** is the starting point once the "*Options*" and "*Save*" dialogue window is opened. This means that once these windows are opened a defined scratch catalogue shall appear. **Once the file is opened**, the drawing may be positioned automatically at the zero point or at the original position acquired from the file.



The position of the drawing or the material, lack of command M03 (only Din 66025) or lack of a reference move may be checked before milling. For NC-EAS(Y) to be able to control, the command given must be active. Changing the zero point makes it possible to move the drawing together with the material.

View

This option includes the settings which define the view of the idle running of vectors, the area of height scan, the raster, tool correction and the absolute and relative coordinates. The size of the raster is arbitrary and is quoted in millimetres or in inches. The view of the particular elements may be switched on or off in the main menu "View". Font types may be defined for absolute and relative coordinates. In the main "View" menu it is possible to turn on or off the [status bars](#) ⁷⁴.

Performance

The NC-EAS(Y) program stores the drawing data in its memory. With a big file, the system may be overloaded. To solve or eliminate this problem the NC-EAS(Y) program has been equipped with a few functions which limit the overloading of the system.

- The processing of big files, for instance the Din 66025 type of files, is purposeful only conditionally. This is why it is possible to quote the size in Mbytes for files where processing is to take place. If the quoted size is exceeded, then the symbol  shall appear on the bottom status bar. The NC-EAS(Y) program loads files also saving on the computer memory and only the shifting and scaling of the drawing data is possible.
- A graphic display of the processing requires a big memory and system capacity / performance. This is why it is possible to switch this option off. If, on the bottom toolbar, the symbol  (see above) is displayed, this indicates that this function is automatically switched off.
- With big files it may take a while for a drawing to be displayed on the screen. To speed up the display, it is recommended to switch on the OpenGL function. OpenGL enables direct access to the graphic card hardware and speeds up the process of drawing. Upon switching on the OpenGL function, it is recommended to visually monitor the drawing process.
- Format GRF files of the NC-EAS(Y) program may be automatically comprised in the zip format. This considerably reduces the size of GRF files, however the loading or saving requires more time.

Editor

It is here that a text editor which reads HPGL, DIN 66025 i Sieb & Maier files is applied / inserted. In the event that one of the said files has been opened by the NC-EAS(Y) program, the file may be edited with the text editor through the main menu "File -> Open with editor". GRF files may not be processed with an external text editor.

5.8 Keypad

The dialogue window "Keypad" may define, for some functions, shortcut keys of the keypad. As such functions are activated directly with the keys, it is recommended that the keys be selected carefully. The whole list of defined keys may be switched on or off with one connector.

Description	Key	Menu command	Icon
Definition of shortcut keys for some functions	none	Settings • Keypad	none

5.9 Joystick

NC-EAS(Y) may control the CNC milling machine with the application of a joystick. Joystick steering may be tuned On on or off with the use of the connector. One of the joystick keys may be defined for changing the speed of the manual advance.

Important: To facilitate joystick steering, Microsoft Managed DirectX9 (see: [installation](#)³⁷) must be installed.

5.10 Unit and scaling

Without determining the appropriate units of measure, the entered drawing shall not be correct. To make the selection of an appropriate unit of measure easier, some of them have been defined (1 mil, 1/40, 1/100, 1/1000 mm). In the event that there is no pre-defined unit of measure, it is possible to enter one's own definition with the use of the keypad keys. Additionally, the entered drawing may be recalibrated by quoting an appropriate scale for X, Y or Z.

Description	Key	Menu command	Icon
Changing the units of measurement and calibration of the entered drawing	none	Settings • Unit and scaling	none

Hint: The measurement unit for file type DIN 66025 may not be changed, this is why the "Scaling" dialogue window appears with no possibility, however, of unit selection.

5.11 File formats

NC-EAS(Y) loads Din 66025, Hpgl or Sieb & Maier file types. This dialogue includes all the settings which remain in connection with reading such files.

Hint: Changed settings do not change files loaded earlier on. Thus parameters must be set before a file is opened.

DIN 66025

In the event that a DIN 66025 file is loaded, the dialogue window "DIN 66025" displays speed rates from the file. The speed rates for the DIN 66025 files are always supplied in millimetres per minute. The NC-EAS(Y) program makes use of the speed rate quoted in millimetres per second, so the speed of the DIN 66025 files is automatically recalculated. If the speed rates are inappropriate, they may be adjusted by providing a vector or by selecting a speed rate from a vector list in the toolbox.

Description	Key	Menu command	Icon
Adjusting the speed of the opened file type DIN 66025	none	Settings • DIN 66025	none

DIN 66025 type files have the following settings available:

- command G02/03 (clockwise or counter-clockwise arc) always relatively
- vector with invert, change of axis Z direction
- letter definition for 4th axis
- selection of arc resolution, from low, medium to high
- definition of transmitters (command M) which may be used for turning on or off various devices through files of Din 66025 type

Hint: Settings in the section "Various" are active in the course of opening a new file of the DIN 66025 type. Alteration of settings does not change the previously loaded file. This is why the parameters must be set first and then the file should be opened.

Hpgl

Sometimes it may be required that the tool, once it immerses in the material, does not commence work immediately but pauses for a particular period of time. This may be achieved with the application of the "Time after tool lowering" function expressed in milliseconds.

Before the actual work commences, a delay may be defined needed for reaching adequate rotation speed of the spindle with a tool. This function is called "**Spindle acceleration time**" and is inactive when working on data in DIN 66025 standard. For Din 66025 the delay time is defined in the file.

Sieb & Maier

There are two different types of drill data (see: [Interpreter of drill data](#)^[12]). Select one of the two types by ticking the type chosen.

5.12 Save the settings

Upon finishing work with the program all the settings are automatically saved. If needed, the settings may be saved in the course of running the program through the activation of the "*Save settings*" function in the main menu "*Settings*".

6 Move

The main menu "Move" includes functions which control the advance of the CNC milling machine.

6.1 Simulation

The simulation function allows for the acknowledgement of the path which the milling tool is to follow in the course of performing actual work. The simulation speed may be changed in the main menu between the options of slowly, average, fast and extremely fast.

Description	Key	Menu command	Icon
Simulation start-up	none	Move • Simulation • Start	none
Choice of simulation speed	none	Move • Simulation • slowly / average / fast / extremely fast	none

6.2 Milling/Drilling

Clicking on the  icon in the horizontal toolbar or pressing the F9 key function starts up the progress of the CNC milling machine. Before the actual start-up, the "Work parameters" dialogue window appears, where it is possible to set the final parameters.

Description	Key	Menu command	Icon
Processing	[F9]	Move • Milling/Drilling	

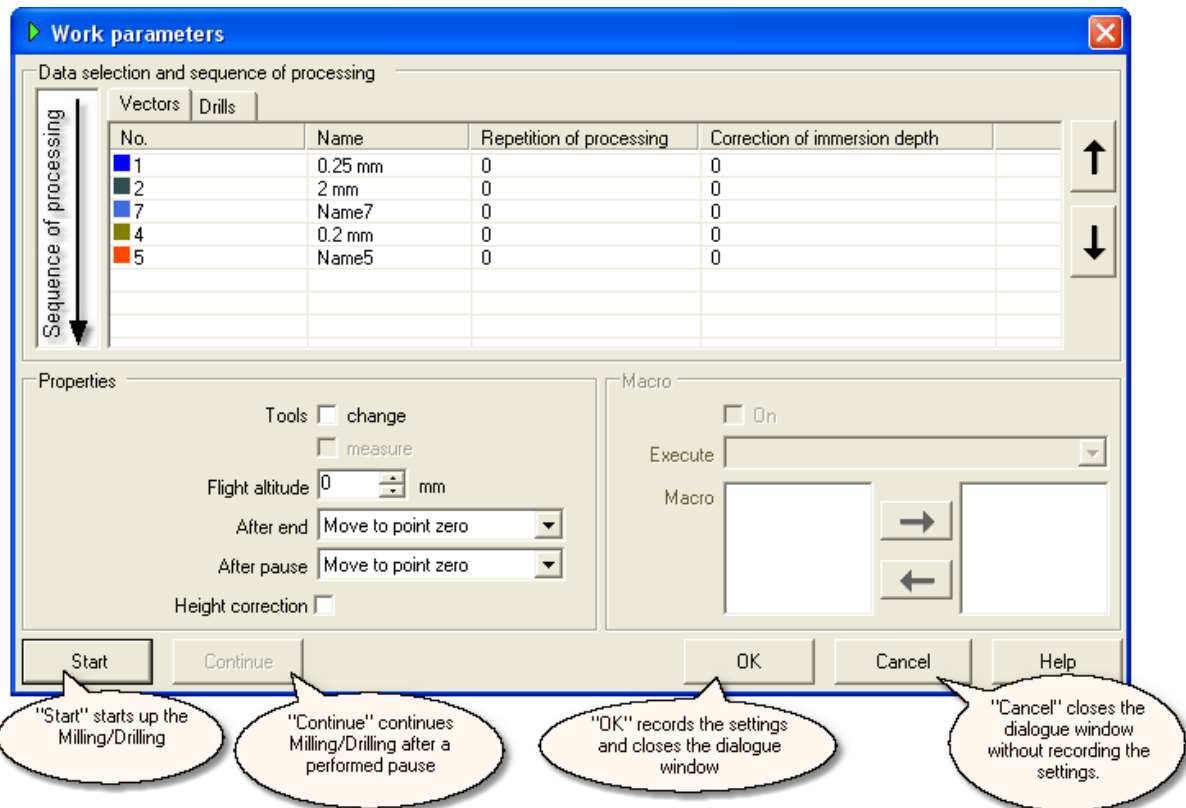

Illustration 1: The "Work parameters" dialogue window.

Selection of data and their sequence of performance

Data of the printed-circuit board consists of files with the HPGL type of vectors and files with drill points of the Sieb & Maier type. The NC-EAS(Y) program may open both the files in one document, process and display them. In this case it is necessary to select the processing data from the tab "Vectors" or "Drill points" (see: illustration 2). In the event that the current document has only the drill points or only the vectors, only one tab is displayed and there is no possibility of choice (see: Illustration 3). Quoting values for **"Repeat processing"** and **"Notch correction in millimetres"** is possible by clicking the adequate line and column in the table. Value 0 of "Repeat processing" parameter indicates that the processing / milling shall be performed once only. Value 1 indicates that the process is repeated one time, etc. This function, along with the notch correction in axis Z, facilitates such processing when the material must be subjected to several working cycles e.g. the milling of deep holes in metal, grinding etc.

Vectors		Drill points
No.	Name	
1	0.2 mm	
2	2 mm	
7	Name7	
4	0.2 mm	
5	Name5	

Illustration 2: Here both vectors and drill points are present so it is necessary to select the data.

Vectors	
No.	Name
1	0.2 mm
2	2 mm
7	Name7
4	0.2 mm
5	Name5

Illustration 3: Here only the vectors are present so there is no possibility of selection.

The vector and drill point lists display all the tools in use in the processing-sequence order. To allow for the possibility of changing the order of the tools, at least two tools must be used. In the event that the "Change tool" option is not switched on, the first tool is always selected for the processing work.

Sequence of processing	Vectors			
	No.	Name	Repetition of processing	Correction of immersion depth
1	1	0.2 mm	0	0
2	2	2 mm	0	0
7	7	Name7	0	0
4	4	0.2 mm	0	0
5	5	Name5	0	0

Illustration 4: The "Tool change" function is switched on. The sequence of processing is changed by selecting a tool and pressing the arrow keys.

Properties

The "Properties" tab includes the following functions:

- The function "**Measure the tools**" may not be switched on without the function "Change tools". Once a tool is changed, the spindle moves to the tool length sensor which shall measure the tool and on this basis an adequate correction shall be performed. A standard micro-switch may be applied as the sensor. Once the measurement is performed, the processing is continued.

Hint: More information on the topic of „*Measure the tools*“ is included in the chapter „[Measure the tool](#)^[37]“

- Flight altitude is the distance between the tool (milling cutter) tip from the material in the course of idle advance (above the material).
- At the end of processing such actions may be defined: "Tool up", "Move to point zero", "Perform reference move", "Tool down" (applicable only with active automatic tool changer), which are performed once milling or drilling is completed.
- After a pause is performed, it is possible to perform such actions as: "Tool up" or "Move to park point". For more information go to chapter '[Pause](#)^[42]'.
- In a situation when the height scan has already been performed previously, the height correction

option may be activated. For more information go to chapter "[Material height scan](#)"^[37].

Macro

The Macro function is described in chapter "[Macros](#)"^[26].

6.3 Manual advance

The "*Manual advance*" dialogue window includes several functions which concern the manual advance of the CNC milling machine. This dialogue window does not block the main menu of the NC-EAS(Y) program and may remain open all the time.

<i>Description</i>	<i>Key</i>	<i>Menu command</i>	<i>Icon</i>
Manual advance of the CNC milling machine	[Ctrl + W]	Move • Manual advance	

The "*Manual advance*" dialogue window includes the following functions:

- Manual advance with the keys
- Manual advance speed
- Move to and fro
- Turn on or off the drill spindle and the pump
- [Material offset](#)^[25]
- [Reference move](#)^[35], [park point](#)^[35], [zero point](#)^[35], [measurement/scan point](#)^[35]

Manual advance with the keys

The CNC milling machine may be operated by pressing the arrow keys (Tabulator and Spacebar) or with the use of the mouse. Each axis is monitored in the process of manual advance. The control over each particular axis may be separately switched on or off. With the function "Relative advance" a move is made of a precisely defined length. To perform the move, the length (segment) must be indicated in millimetres and an appropriate arrow key must be pressed. The arrow key indicates the direction of the move. There are three boxes to enter the move segments, and it is possible to switch between them without the necessity to enter the values again.

Manual advance speed

Here three different manual advance speed rates for axes X, Y, Z and A are defined, expressed in millimetres per second. The selected speed rate is used in the "Key move" and "Move to and fro" functions. Additionally, a very slow advance (5 steps per second) is available. This advance mode is used for the function "Manual advance with keys" and facilitates precise positioning on axis Z.

Move to/Move to and fro

Functions "*Move to*" and "*Move to and fro*" include the possibility of controlling the machine. In both functions the destination point is determined by entering relevant data with the use of the keypad. When the "*Start*" key is pressed a particular operation is started up, and when the "*Cancel*" key is pressed the operation is stopped.

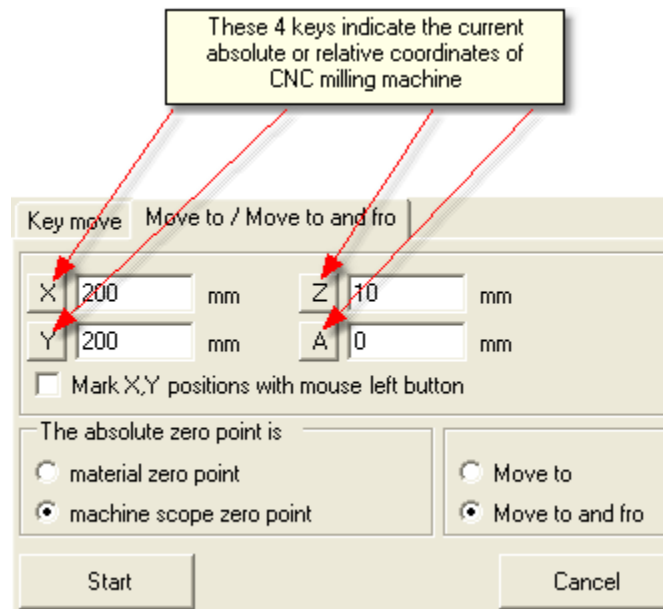

Illustration: The "Move to" and "Move to and fro" functions make absolute advance of the CNC milling machine possible.

The position may be entered into the X, Y boxes with the use of the mouse (left mouse key). To make this possible the "Insert positions x,y with mouse" box must be ticked.

Drill spindle and pump

The power feed of the drill spindle motor and the pump may be turned on or off in the course of manual advance. In this case the machine functions just like a standard milling machine with control over the path length.

6.4 Height of drawing measurement

To transform HPGL files into 3D type files, the drawing must be divided into small vectors and then the height of the vectors must be measured at their starting and final points. The resulting measurements are saved along with the HPGL coordinates as file Din 66025.

Description	Key	Menu command	Icon
Divide the drawing into small vectors	none	Process • Drawing • Split vectors	none
Measurement of height of drawing	none	Move • Height measurement · Drawing measurement	none
Show starting and final points of vectors graphically on the screen.	none	View • Starting and final points of vectors	none

6.5 Reference move, and moves to positions

In the "Move" main menu or in the menu of the "Manual advance" dialogue window it is possible to perform reference moves or a move to the park point, the zero point or the measurement/scan point.

Description	Key	Menu command	Icon
Reference move	[F12]	Move • Reference move	

Move to park point	[F10]	Move • Park point	none
Move to zero point	[F11]	Move • Zero point	
Move to measurement point	none	Move • Measurement point	none

For the *CNC* machine to recognise the position of the *CNC* machine axis, a reference move must be made, for example each time the NC-EAS(Y) program is started up or after a move is interrupted. In the "Reference move" dialogue window the axes, which are to perform the reference move, are selected. A reference move may also be performed manually in the main menu "View". Once the reference move is performed, the absolute coordinates are deleted (see: [Status bars](#) ^[7]).

In order to perform a move to the zero point, park point or the measurement point, the points must first be defined in the "[Position](#)" ^[24] dialogue window.

6.6 Calibration of the tool-length sensor

To be able to use the tool-length sensor, its calibration must once be performed. Calibration of the sensor is performed with the use of the calibration assistant.

Description	Key	Menu command	Icon
Calibration of the tool-length sensor	none	Move • Tool • Measure the tool	none
Delete the measurement values	none	Move • Tool • Delete the measurement value	none

The assistant performs the following actions, in this order:

1. Reference move

For the position of the *CNC* milling machine to be adequate, a reference move must be performed. If the reference move has already been performed before, this step may be skipped by clicking "Continue".

2. Table height measurement

Please fix a chosen tool and move in axis z till the tool tip touches the *CNC* milling machine table. The saved height of the *CNC* milling machine results, together with the material thickness, in a new axis z height at point zero. Please note that the material thickness starts at the table height and finishes at the top edge of the material (see: Illustration).

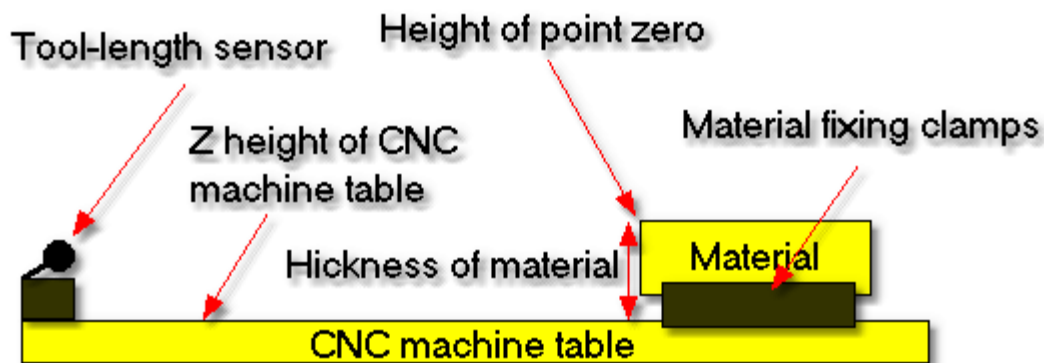

Illustration: Height of the machine table and thickness of material result in the height of point zero

Hint: In the "Positions" dialogue window the new height of point zero may be defined by providing the

material thickness data.

3. Measurement of the height of the tool-length sensor

Now a move is performed to the sensor in order to measure its height.

4. Summary

This last page of the assistant shows the height of the table and the height of the tool-length sensor at its start. By clicking on the "Complete" option the values are saved and the assistant is closed.

Hint: If the tool-length sensor is not to be used again, the calibration data should be deleted.

6.7 Measure the tool

In order to measure the length of the tool, calibration of the tool-length sensor must once be performed.

Description	Key	Menu command	Icon
Manual measurement of tool length	none	Move • Tool • Measure tool	none

If several parts are to be produced with the use of the same tool (serial production), it is wise to perform the tool measurement just once. This way a multi-time performance of the tool measurement before the milling of each part may be avoided. To avoid a multi-time performance of the tool measurement, it is also necessary to turn off the change and measure the tool functions in the "Work parameters" dialogue window.

6.8 Material height scan

In order to enable the engraving of an uneven material surface, the material height measurement (scanning with an appropriate raster) may be performed first. With the aid of thus acquired data, correction of the Z axis is performed in the course of engraving or milling; in this case the milling cutter penetrates the material to an unchanging and constant depth (+/- tolerance).

Description	Key	Menu command	Icon
Material height measurement/scan	[F11]	Move • Material height scan	

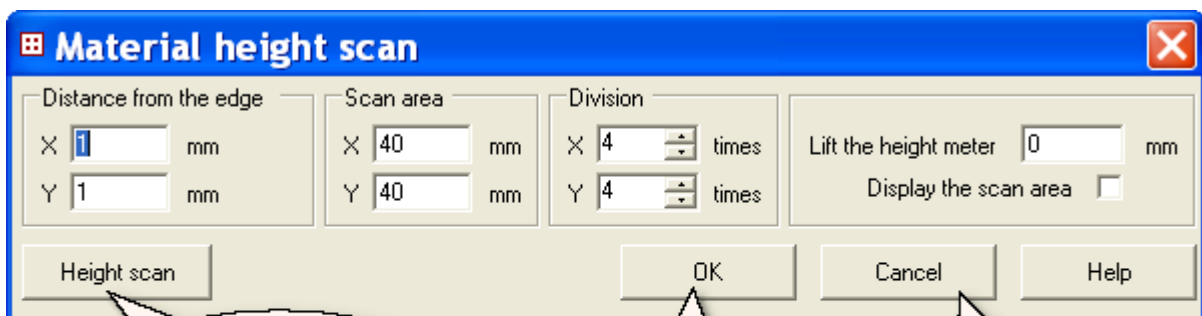

"Height scan" records all the settings, closes the dialogue window and starts up the height scan

"OK" records all the settings and closes the dialogue window

"Cancel" closes the dialogue window without saving the settings

Illustration: The "Material height scan" dialogue window parameters.

The dialogue window parameters in detail:

Distance from the edge

To avoid error measurement on the material edge, the area under measurement should not be in contact with the edge of the material.

Scan area

Here the size of the area under measurement is defined (in millimetres) in X and Y directions.

Division

The number of measuring/test points, that is the so-called **raster**, is calculated by the program on the basis of dividing the length and the width of the material by the value quoted in the material division box. For example, with the length of material equal 100 mm and the stand-off ratio (division factor) equal 5, we shall come up with 6 measuring points distributed every 20 mm. With considerably even surfaces, to achieve a sufficient height correction precision, few raster points are required. For control purposes the scan area may be displayed on the screen.

Lift the height meter

This height is the distance between the tip of the tool and the material in the course of an idle move.

Display the scan area

Switch on or off the display of the height measurement area.

Height scan deviation

At the end of the measurement, NC-EAS(Y) calculates the ideal values of a particular measurement for each raster (square). The deviation is the difference between the ideal value and the measurement value. The highest deviations are displayed. If a deviation is higher than 0,1 mm then the raster may have a bulge or a notch. In such an event it is advisable to perform a height scan once again but with a smaller raster.

Hint: A height scan deviation may also be displayed in the menu "*View -> Height scan deviation*".

Export/Import of height scan data

The height measurement data may be recorded through the main menu "*File -> Height scan data -> Export*" as a DXF file (lines or points), Din 66025 file, a text file or the SCAN file type of the NC-EAS(Y) program. The SCAN type file may be retrieved again later. The height scan deviation of the retrieved SCAN type file may be quoted back from the main menu "*View ->Height scan deviation*".

6.9 Tool change

This function is applicable exclusively along with the [automatic tool changer](#)^[22]. The function facilitates automatic setting aside or picking up of tools.

7 Data editing





The NC-EAS(Y) program has numerous functions meant for use when editing a drawing. All such functions can be found in the main menu "*Edit*" and most of them may be activated by clicking the icons on the vertical toolbar. The "*Undo*" function makes it possible to undo the last 10 changes.

7.1 Insert, copy, rotate, mirror reflection and expand

The main menu "*Edit -> Drawing*" has functions for the purpose of editing a drawing. A given drawing or its part may be positioned differently, changed or copied. All the functions have been constructed similarly and are made up of the same or similar elements.

The range defines the area (material or machine area) which is subject to positioning. **Example:** A drawing may be positioned in the centre of the material by choosing the "*Material*" scope.

The displayed groups help to select the data which is subject to editing. **Example:** In the event that only the drill points are to be moved with the use of the "*Insert*" function, the "*Drill points*" group must be selected. Depending on the type of data at your disposal, the particular groups are on or off.

Description	Key	Menu command	Icon
The drawing may be positioned in the centre or with relation to the zero point or the machine area	none	Edit • Drawing • Locate	
The drawing may be rotated (in degrees) clockwise or counter-clockwise	none	Edit • Drawing • Rotate	
Mirror reflection of the drawing may be performed on axis X or Y	none	Edit • Drawing • Mirror reflection	
The drawing may be copied a multitude of times	none	Edit • Drawing • Copy	
The drawing may be expanded by quoting the margin on the material or the machine area	none	Edit • Drawing • Expand	

7.2 Selection window

The "Selection window" allows for editing particular drawing elements with the mouse (moving, rotating, copying or deleting). The first operation to be performed is the selection of relevant data type, that is the "*Vectors*", "*Poly-lines*", "*Drill points*" or "*All*", by clicking the  icon on the horizontal toolbar. The graphic range of the drawing shall now display the mouse cursor (a cross) and the appropriate data may be selected now. By pressing the left mouse key, moving the mouse, and pressing the left mouse key again a rectangle is pulled to enclose the drawing or its part. Eventually, the drawing or a part of the drawing is enclosed in the rectangle (see: Illustration).

Description	Key	Menu command	Icon
Selection window allows for the selection (with the mouse) of a drawing or a part of the drawing for editing	none	none	

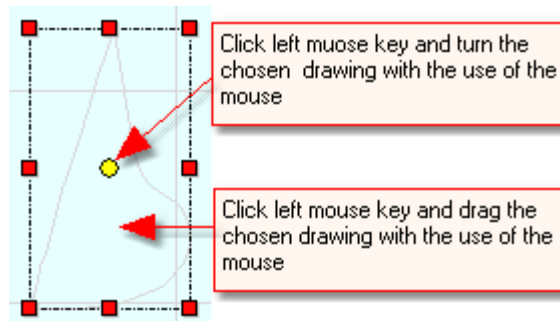



Illustration: The content of the selection window is rotated with the use of the mouse.

Once the data has been selected with the use of the mouse, a particular operation may be conducted by choosing a key function and, by pressing the left mouse key, clicking on the content of the selection window.

Description	Key	Menu command	Icon
Delete	[Del]	Edit • Selection window contents • Delete	none
Copy	[Ctrl +C] plus left mouse key	Edit • Selection window contents • Copy	none
Move	[Ctrl +X] plus left mouse key	Edit • Selection window contents • Move	none
Rotate	Selection window centre  and left mouse key	none	none

7.3 Change of tool number and the direction of milling

The direction of milling and the change of the tool number is performed in the "Properties" dialogue window. In order to be able to change the properties, the drawing data intended to be changed must be selected with the use of the "Selection window" ³⁹. The "Properties" dialogue window displays the current tool number of the selected data. If the selected data has more than one tool, then the tool number is not displayed. Now the new tool number may be entered or the direction of milling and the "Change" key performs the required changes.

Description	Key	Menu command	Icon
Change of tool number and milling direction	none	none	

7.4 Removing drill points, height scan data and tool diameter correction

The "Edit -> Delete" menu allows for the removal of the drill points and the height scan data and the tool correction.

Description	Key	Menu command	Icon
Remove tool diameter correction	none	Edit • Remove • Tool diameter correction	none
Remove drill points	none	Edit • Remove • Drill points	none
Remove height scan data	none	Edit • Remove • Height scan data	none

7.5 Correction of the trailing cutter

Prior to the performance of cutting, the position of the trailing cutter with respect to the axes is not known. Thus the Y direction must be set accordingly (see: Illustration 1).

Description	Key	Menu command	Icon
Correction of the Trailing cutter	none	Edit • Trailing cutter correction	none

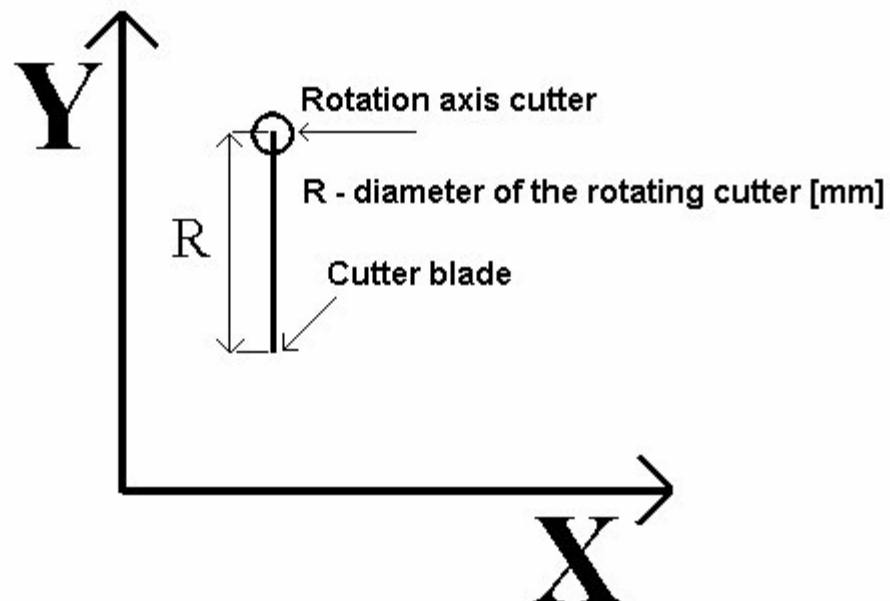

Illustration 1: Starting point of the trailing cutter.

Immediately after the start, the cutter must be adjusted with the help of the axial section in the Y direction (see: Illustration 2).



Illustration 2: Axial section in the Y direction.

In the "Trailing cutter correction" dialogue window the diameter of the trailing cutter is corrected. **Cutter offset** is the distance between the rotation axes of the cutter and the cutter blade (diameter of the cutter). **Angle start** defines the angle deviations for subsequent paths. The angles, in the course of the correction of the trailing cutter path, are calculated. The bigger the angle start parameter, the more rounded the angles. The recommended value equals 8 degrees. The **Scale** parameter expands the drawing. Once the correction of the trailing cutter is calculated, the drawing may no longer be expanded as the cutter's diameter has changed as well.

7.6 Pause

The pause enables milling to be continued from any given location. The location may be set manually or in the course of milling by clicking the  icon on the horizontal toolbar. In the numerical space for introducing data in the "Pause" dialogue window, the number of the vector must be entered as the location of a pause. With the aid of the group, a choice is made between the grill points and the vectors. The parts of the drawing which are to be milled are displayed in grey colour.

<i>Description</i>	<i>Key</i>	<i>Menu command</i>	<i>Icon</i>
Locate position, in the course of milling	none	none	
Locate position, move/shift	none	Edit • Pause	none

7.7 Tool diameter correction

Correction of the tool diameter determines if a tool needs to be moved to the left or to the right of the drawing vector. NC-EAS(Y) facilitates the tool correction to the left, right, inside or outside (see illustrations 1 to 4). The smoothing factor should have the value, in most cases of small vectors, from 15 to 45. The smoothing factor changes the data generated by the tool correction. Original vectors remain unchanged. The higher the factor of smoothing, the fewer the small vectors and the thicker in outline the tool diameter correction. Tool correction may only be performed for Hpgl files.

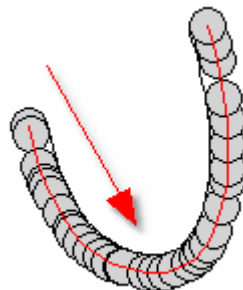

Illustration 1: Tool correction to the left, the arrow indicates the vector direction

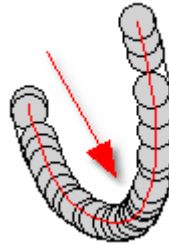

Illustration 2: Tool correction to the right, the arrow indicates the vector direction

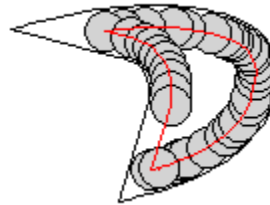

Illustration 3: Tool correction to the inside

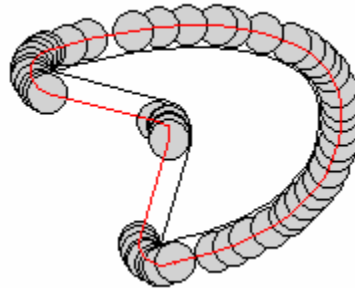

Illustration 4: Tool correction to the outside

7.8 Path optimisation

Path optimisation sorts out the data, removes small vectors (smoothing factor) and shortens the working time of the CNC milling machine. Tool correction may be performed for all or for only one tool.

8 Problem solving

Problem	Possible solution
There is no connection with the drive electronics of EAS USB Controller.	<p>EAS USB Controller</p> <ul style="list-style-type: none"> • Disconnect the USB cable and plug in again. • Change the USB cable to a different one. • Turn off the electronics and turn it on again. • End the program and restart. • Check in the Windows system tool manager if the electronics drive is recognized by Windows. The USB-Controller section must state: EAS USB Controller
In the course of a reference move at least one axis moves slowly from or to the axis connector.	<ul style="list-style-type: none"> • The reference move directions have been set wrongly and must be changed. For a correct setup of the pin connectors please use the "Reference pin assistant". More information in the "Machine parameters" chapter.
The <i>CNC</i> milling machine can be heard working but does not operate.	<ul style="list-style-type: none"> • The stepper motors are not supplied with enough electric current which, in case of stepper motors, must be inverted. More information in the "Machine parameters" chapter.
The <i>CNC</i> milling machine works well at the beginning. After a few minutes either communication is interrupted or inexplicable errors occur.	<ul style="list-style-type: none"> • Probably the computer switches off on its own after a few minutes. Please turn off the Power Management in BIOS. Please also check the power management in the options of Windows management panel.